

CHF1111TOP-GAS



Gas combi oven 7 trays 1/1 GN with touch screen

Its performance makes it the ideal ally of every gastronomy professional. The new 11-tray Millennial gas oven guarantees optimal results in a short amount of time. Captivating design, technology and performance at the highest levels, a capacity of 11 GN1/1 trays.

A loyal ally for medium/large restaurants that can handle even the most complex recipes with maximum simplicity. 500 programmable recipes, 42 languages, up to 24 h delayed cooking programs, and 5 ventilation speed settings are just some of the features that characterize all the Millennial line.

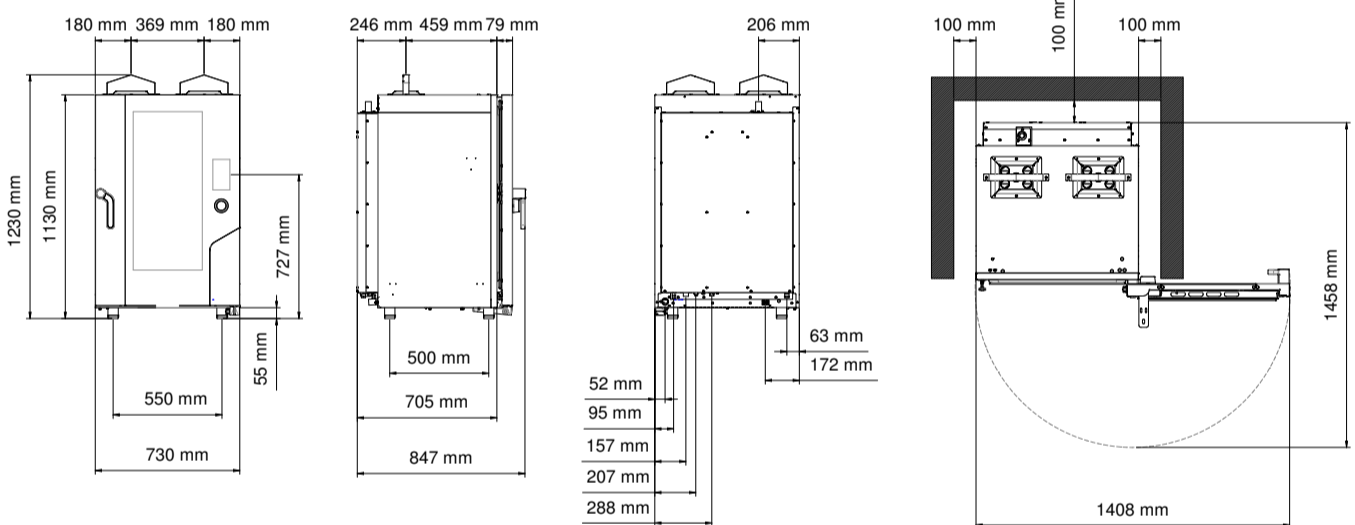

Dimensional features

Dimensions (WxDxH mm)	730 x 850 x 1230
Weight (kg)	152
Distance between rack rails (mm)	68

Electrical features

Thermal supply (kW)	18
Frequency (Hz)	50/60
Voltage (V)	AC 220/230
N° motors	2 bidirectional
Boiler (kW)	/
Protection against water	IPX3

Functional features

Power	Multigas (tested for natural gas)
Capacity	N° 11 trays/grids 1/1 GN
Type of cooking	Semistatic + ventilated
Steam	Direct steam controlled by touch screen (10 levels)
Cooking chamber	AISI 304 stainless steel
Temperature	30 - 260 °C
Temperature control	Digital probe thermometer
Control panel	Touch screen
N° programs	500
Programmable cooking steps	10
Pre-heating temperature	180 °C
Pre-heating function	Programmable
Door	Right side opening Ventilated Inspectionable glass
Feet	Adjustable

Equipment

Cardboard box dimensions with pallet (WxDxH mm)	790 x 905 x 1300 mm
Lateral supports	1 dx + 1 sx
Cable	Single-Phase [3G 1,5]-L=1600 mm
USB port	
Multipoint core probe cod. CHSC3P	
Support for core probe	
Automatic washing system integrated	
Condensate collection bowl, with drain on door	
Hinge with door locking for openings adjusted at 60°, 90°, 120°, 180°	
Nozzle for LPG	

Plus

Patented fan guard system Airflowlogic™	
Patented system for direct steam Humilogic™	
Patented system for cooking chamber drying Drylogic™	
Available on request at the order	Left side opening door
Humidity management software	
Wi-Fi communication system	
Knob for quick selection of the touch screen	
Programmable oven start	
N° 40 recipes stored	
Control panel in 42 languages: Arabic, Armenian, Azerbaijani, Bahasa (Indonesia), Bahasa (Malaysia), Bosnian, Bulgarian, Chinese, Croatian, Czech, Danish, Dutch, English, Estonian, Finnish, French, Georgian, German, Greek, Hungarian, Icelandic, Italian, Japanese, Kazakh, Latvian, Lithuanian, Norwegian, Persian (Iran), Philippine, Polish, Portuguese, Romanian, Russian, Serbian, Slovenian, South Korean, Spanish, Swedish, Thai, Turkish, Ukrainian, Vietnamese	
HACCP system	
Adjustable door hinges	
Regulation 2016/426/UE	